

# **Determination of O<sub>2</sub>, CO, H<sub>2</sub>O Concentrations and Gas Temperature in a Coal-Fired Utility Boiler using a Wavelength-Multiplexed Tunable Diode Laser Sensor**

Andrew D. Sappey, Jim Howell, Pat Masterson, and Henrik Hofvander  
Zolo Technologies, Inc.  
4946 N.63<sup>rd</sup> Street, Boulder, CO 80301

and

Jay Jeffries, Xin Zhou, and Ron Hanson  
Department of Mechanical Engineering  
Stanford University, Stanford, CA 94305-3032

## **Abstract**

Here we describe results obtained during a preliminary measurement campaign from a novel combustion sensor based upon multiplexed tunable diode laser spectroscopy (TDLAS) applied to coal-fired electric utility boilers. The totally fiber-coupled sensor utilizes unique multiplexer technology developed for telecommunication applications to combine five measurement wavelengths to simultaneously probe O<sub>2</sub>, H<sub>2</sub>O, and CO concentration as well as temperature in the combustion zone of an 220 MW utility boiler. In spite of significant transmission losses due to obscuration by coal dust and fly ash (average transmission =  $1-5 \times 10^{-4}$  ten meters above the coal injectors), we are able to measure temperature and monitor the target species. This work represents several notable accomplishments including the first use of an all fiber-coupled device for measurements on a coal-fired boiler and the first simultaneous detection of all three species (CO, H<sub>2</sub>O, and O<sub>2</sub>) and temperature in a coal-fired utility boiler. Current work includes reduction of mode noise that is especially evident in the O<sub>2</sub> measurements and the accurate measurement of linestrengths needed for the weak water vapor absorption lines used over this long path. This sensor should ultimately provide the best available information to institute feedback control to optimize combustion efficiency and minimize pollutant emissions.

**Keywords:** Absorption, Optical Absorption, Temperature, Combustion Diagnostics, Sensor for Practical Combustor

## Introduction:

Emissions from coal-fired utility boilers are the focus of increasing scrutiny. Early emphasis on reduced emissions of NO<sub>x</sub> and SO<sub>x</sub> is now being coupled with a desire to reduce CO<sub>2</sub> emissions. These goals can be simultaneously achieved by improving the efficiency of the combustion process in the boiler. Efficiency improvements can produce several immediate benefits. First, savings on the order of \$1M/year in coal accrue for an average 600 MW boiler with an efficiency increase of only 1%, and second, a simultaneous reduction in CO<sub>2</sub> emissions is realized. In the near future, one can envision that CO<sub>2</sub> credit arbitrage will become the norm just as NO<sub>x</sub> credit trading occurs now. Third, efficiency improvement can also reduce NO<sub>x</sub> emissions enabling the utility to sell NO credits or avoid expenditures for pollution-control equipment. For the average 600 MW boiler, a 20% NO reduction amounts to elimination of 1800 tons per year of NO<sub>x</sub>, which is valued near \$4,500,000 at the current average NO<sub>x</sub> credit price (varies by state and year). Fourth, efficiency improvement via complete combustion would also improve some of the deleterious conditions that can occur in boilers such as slagging and corrosion that will ultimately save money in maintenance costs for the utility.

In general, coal-fired boilers are poorly controlled devices with tuning or optimization occurring at monthly or yearly intervals rather than on a continual basis. There are many reasons for this *laissez faire* situation including a lack of combustion parameters to alter, a lack of sensors to provide useful information to feed back into the optimization process, antiquated equipment, and a general ambivalence on the part of some utilities.

However, this state of affairs is beginning to change. A few companies have developed optimization software that takes current sensor inputs from diverse sources such as oxygen sensors, CEMs measuring pollutants, airflow measurements, and coal loading measurements and optimizes the combustion process. Improvements on the order of 0.5 - 1% for heat rate and 20% NO reduction are routinely attained.[1] However, all information regarding combustion efficiency currently comes from sensors placed well downstream of the boiler. Often these sensors are extractive, which can lead to serious measurement errors if great care is not taken in their installation. One expects that better measurements could be made if sensors were available that would measure combustion parameters directly in the combustion zone without extractive probes. Clearly this presents a challenge due to the extremely hostile environment of the boiler. Optical diagnostics have a significant advantage in this regard since no intrusive probes are required.

Tunable diode laser spectroscopy (TDLAS) for combustion diagnostics has been developed over the last 20 years by a variety of practitioners. Although the majority of this work is conducted in well-controlled, laboratory-scaled flames, there are some notable exceptions. Furlong et al. used water vapor temperature to control CO and unburned hydrocarbon emissions from a 50kW incinerator.[2] Allen et al. have conducted a variety of experiments in large scale test facilities modeling industrial furnaces, gas turbine engines, and SCRAMJETs.[3] Silver et al. have utilized diode lasers for combustion diagnostics in fielded microgravity combustion tests.[4] Teichert et al. have demonstrated quantitative detection of CO, H<sub>2</sub>O concentration and temperature in a coal-fired utility boiler using a multiplexed wavelength sensor operating

at 813 nm and 1.56 microns.[5] Deguchi et al. measured CO and O<sub>2</sub> concentration in a waste incinerator with the ultimate goal of reducing dioxin emissions. Reduction of CO from 12 ppm to 8 ppm was realized.[6] The researchers at Stanford have demonstrated quantitative species detection and temperature measurement in a variety of realistic aerospace combustion applications including pulse detonation engines, SCRAMJET combustor, and gas turbine combustor sector test rig using multiplexed wavelength sensors.[7,8]

There exist two solutions to agile-wavelength coverage of multiple absorption transitions (scanned wavelength and multiplexed wavelength). Unfortunately, the present technology for single-laser wavelength scanning does not provide the time response needed for combustion control nor does it provide sufficient wavelength coverage for the entire range of interesting transitions which extends from 760 nm to 2.3 microns for TDL sensing of O<sub>2</sub> and CO (in the first overtone). A wavelength-multiplexed approach combines multiple diode laser beams into a single beam which is then transmitted across the combustor, collected onto a receiver fiber, and dispersed to individual detectors for rapid time response. We have successfully applied this approach to pulse detonation engine diagnostics [7] and have made demonstration measurements in a SCRAMJET combustor test rig [8].

The sensor described in this paper incorporates five measurement and two alignment wavelengths, which are multiplexed into a single-mode optical fiber, transmitted through a coal-fired power plant combustor, recollected into an optical fiber, dispersed with a novel dispersive device, and detected on separate detectors. A schematic diagram of the sensor is shown in Figure 1. This all-fiber-coupled design

allows the sensitive electronics and lasers to be located in the power plant control room as much as a kilometer from the combustor.

The fiber-coupled multiplexer and de-multiplexer used in this sensor is of a new design that overcomes many of the problems encountered by multiplexed TDL sensors for practical combustion systems. It is useful to multiplex the laser beams into an optical fiber as this insures that all transmitted beams follow the same optical path through the combustor. Fiber combiners work well for this application, but in general the transmitted intensity of these devices scales as  $(1/2)^n$ , where  $n$  is the number of lasers multiplexed. Thus, for many colors fiber combiners are quite inefficient; this problem is exacerbated when the wavelengths of the lasers are widely separated as needed to monitor important combustion species such as  $O_2$ , CO, and  $H_2O$ .

To de-multiplex the lasers either dispersive optics or FM techniques are required. Furlong et al demonstrated the use of a multiplexed sensor to monitor CO (near 1.6 $\mu$ m) and  $H_2O$  (2 colors near 1.4  $\mu$ m) to control emissions from a 50kW incinerator [2]. Oh et al. have utilized very innovative two-frequency FM techniques in order to demultiplex two wavelengths after passing through the combustion zone.[10] In this case, the various detection wavelengths are not physically separated but instead are each encoded using a different modulation frequency that then facilitates discrimination and separation electronically. The FM technique works well but is limited to only a few wavelengths. [10] Liu et al. have utilized dispersive de-multiplexing for their three-color water vapor sensor to measure temperature at kHz update rates in SCRAMJET and gas turbine combustors;[8] however, these prototype systems used general purpose components on a breadboard requiring regular alignment and purging of ambient water vapor. [8]

The novel multiplexer and demultiplexer technology used here was designed to operate with many wavelengths (>40) with the same level of loss as experienced with only a few wavelengths. Thus, this technology is ideal for applications in which many wavelengths must be combined. The device utilizes free-space diffraction grating technology in conjunction with a hybrid micro-optics and macro-optics design to achieve its functionality. In addition, this grating can be used with acceptable efficiency at a variety of other interesting combustion wavelengths. The broadly spaced wavelengths necessary for detection of CH<sub>4</sub>, CO<sub>2</sub>, H<sub>2</sub>O, and CO can all be multiplexed using a grating device by taking advantage of the good efficiency of an echelle grating for many different orders. For the sensor described here the lasers are multiplexed using 6<sup>th</sup>, 5<sup>th</sup>, 7<sup>th</sup>, and 6<sup>th</sup> or 4<sup>th</sup> orders, respectively. This device is assembled in a physical package 15x5x2cm. Using a combination of micro and macro optics, the dispersion device does not require user adjustment; thus, it is hermetically sealed to avoid the need for purging of ambient gases. Thus, this technology provides an all-fiber-coupled, robust solution for wavelength-multiplexed sensors.

This novel multiplexer/demultiplexer, originally developed for telecommunications applications, is the heart of the sensor used to measure combustion parameters in a coal-fired utility boiler. We multiplexed light from five measurement lasers and two visible alignment lasers into a single optical fiber optimized for single-mode transmission down to 1280 nm. After exiting 500 meters of this single-mode fiber, the light was collimated by an optimized triplet lens and pitched across a 13-meter path through a tangentially-fired, coal utility boiler. After exiting the boiler, the light was “caught” using the same triplet lens design as used for the pitch optic and coupled into

multimode fiber, separated according to wavelength by the demultiplexing technology described earlier, and detected by either Silicon or InGaAs detectors depending on wavelength.

Several measurement locations were attempted, and we were able to obtain measurements as close as 10 meters downstream (position A) of the last coal injection ports where the opacity was such that visual observations through the fireball were impossible. We also made measurements 13 meters downstream (position B) of the last coal-injection port where the opacity was sufficiently low that one can see through the boiler most of the time. The average transmission at position A was  $1 - 5 \times 10^{-4}$  for any of the wavelengths although there is significant fluctuation in this transmission. Transmission levels 20 times higher (at the  $2 \times 10^{-3} - 10^{-2}$  level) are sometimes observable as well as transmission levels that are so low that essentially no light is detectable. Transmission levels are sufficient to achieve a 50% duty cycle for data processing at position A. Optical access closer than position A to the last set of coal-injectors was not available at the time of the measurements.

This work differs from previous measurements on coal-fired boilers by Teichert et al.[5] and Deguchi et al. [6] in several ways. In particular, we demonstrate for the first time here the use of an all-fiber-coupled optical multiplexing (demultiplexing) technology described earlier. This technology allowed us to propagate seven independent wavelengths across a 13-meter path length in the coal-fired boiler to sense combustion temperature, O<sub>2</sub> concentration, H<sub>2</sub>O concentration, CO concentration, and provide two strong visible alignment beams. The oxygen concentration in the fireball is especially important because boiler overfire air is typically controlled to produce an excess

concentration of approximately 3-4% to insure complete combustion. In addition, we demonstrate the first use of single and multimode switches in our sensor to quickly switch the measurement location to different parts of the boiler and fireball.

## **Experimental**

Measurements were made in two locations downstream (position A and B) of the last set of coal injectors on the tangentially-fired boiler at the Valmont station in Boulder, CO. The boiler ran at full load burning Powder River Basin (PRB) coal and produces 220 MW of electricity. These measurement positions are located  $\sim 10$  meters (position A) and  $\sim 13$  meters (position B) above the coal injectors. For these measurements no attempt was made to hard-mount the pitch and catch optics to the boiler; instead, the pitch and catch optics were located on tripods at a standoff distance from the viewport of  $< 0.5$  meter. The pre-existing optical access ports consisted of rectangular apertures 15 cm tall by 5 cm wide. The pitch and catch optics were manually aligned for these initial measurements using co-multiplexed red HeNe and green frequency-doubled Nd:VO<sub>4</sub> laser beams. Future versions of the sensor will incorporate an automatic alignment feature to find and maintain optimum alignment. The path length through the boiler traversed by the laser light was 13 meters. The pitch/catch alignment was stable over a period of hours, but a slight daily adjustment improved the signal levels.

### **Laser line selection**

For most previous applications of wavelength-multiplexed absorption spectroscopy, features were chosen with large linestrengths due to the short pathlengths, e.g.  $\sim 15$  cm for the SCRAMJET combustor exit.[8] However, in this experiment the long path necessitates the choice of transitions with relatively low linestrengths to insure

optically thin conditions for the absorption measurements. Table 1 shows the lines chosen based upon HITEMP simulation [11]. (This table has been removed because it contains proprietary information, but all water lines occur between 1300 and 1400 nm). The water lines chosen for temperature measurement were selected based on their lower state energy, their relative spectral isolation, and their predicted absorbance for a 10 m path. Lines with lower state energies ranging from 1000 – 3500  $\text{cm}^{-1}$  were selected to maximize sensitivity to temperature in the expected temperature range and minimize absorption by ambient water vapor near the pitch and catch optics. Water vapor absorbance levels between 5 and 20 % for a 10 m path were selected. We chose to probe the R(24) line of CO to minimize the potential for spectral interference from water absorption as also used in the work of Teichert et al. [5] and Deguchi et al. [6]

Each of the selected water and CO transitions was targeted with an individual distributed feedback (DFB) laser (NEL). An Avalon Photonics VCSEL was selected to probe  $\text{O}_2$  transitions near the R-band head of the  $b^1\Sigma_g^+ - X^3\Sigma_g^-$  system at 760 nm. The laser wavelength was injection current tuned across the transition at 2kHz; the DFB scan ranges were  $\sim 2\text{cm}^{-1}$  while the VCSEL scan range was  $\sim 7\text{cm}^{-1}$ .

### **Fiber-optic technology**

The optical multiplexer consists of a free-space diffraction grating platform using a “hybrid” optical configuration (employs both micro-optics and normal macro-optics) for collimating the incoming beam and coupling the output beam. Briefly, the focal length of the device is approximately 30 mm, and it utilizes a 171.4 line/mm,  $54.6^\circ$  blaze angle echelle diffraction grating in a Littrow configuration operating in 6<sup>th</sup> order to multiplex wavelengths in the telecommunications C-band from 1520 – 1565 nm. This

wavelength range encompasses the CO transitions at ~1559 nm used for detection here; however, clearly, it is insufficient to cover the entire region of interest for combustion diagnostic applications. However, echelle gratings have a significant advantage in this regard in that they can be simultaneously efficient in multiple orders (wavelength ranges). Thus, the 7<sup>th</sup> order covers all of the water transitions of interest from 1300 nm – 1400 nm with high efficiency and includes the 760 nm oxygen transitions in 12<sup>th</sup> order. The average insertion loss is 1.5 dB at 1559 nm and similar efficiency is obtained for the water detection wavelengths (1300-1400 nm) and oxygen near 760 nm.

### **TEM mode issues**

#### **Pitch-side mode noise at 760 nm**

Mode noise is caused when, as a function of wavelength, the mode distribution emanating from the fiber changes. If all light regardless of mode can be multiplexed, pitched, caught, demultiplexed, and detected then changes in mode distribution as a function of wavelength are irrelevant. However, in practice the beam is always vignetted by slight misalignment in the multiplexer or the pitch and catch optics or by beam steering which then leads to undulations that appear to be etalon-derived in the baseline. We strongly believe that these effects are not the result of etalon behavior, but rather residual mode noise caused by vignetting of the beam with a wavelength-dependent transverse distribution.

The current sensor uses single-mode, SMF 28 fiber throughout the pitch side optical train to minimize mode noise. This fiber provides single-mode operation at wavelengths longer than 1280 nm, and so, for the three water detection wavelengths and the CO detection wavelength, there is no pitch-side mode noise. Unfortunately, the 760

nm light necessary for detection of O<sub>2</sub> can propagate through the fiber in several low-order TEM modes leading to residual mode noise in our measurement. Methods to overcome this mode noise constitute one of the key pieces of intellectual property that allow the sensor to operate properly.

### **Catch-side mode issues**

Multimode fiber must be used on the catch side for several reasons. First, beam steering and the effect of relative and dynamic misalignment of the pitch and catch optics due to mechanical vibration of the boiler produce time-varying single-mode catch efficiency. Multimode fiber provides a much larger spatial target and numerical aperture and thus minimizes the variations in coupling efficiency. Second, the beam experiences dramatic wavefront distortion in propagating through the combustion zone. As a result, the coupling efficiency into single-mode fiber would be quite poor even if good alignment between the pitch and catch optics could be maintained. Consequently, multimode fiber is used on the catch side optical train. However, once again this leads to the potential of mode noise, and in this case, mode noise is possible at all wavelengths; not just 760 nm. Once again, Zolo has developed significant intellectual property regarding means to virtually eliminate catch side mode noise.

The pitch and catch optics are triplets of proprietary design that are 0.13 NA, 13.5 cm focal length lenses that collimate the beam to a diameter of approximately 3.0 cm. The expanded beam aids transmission through the boiler since many of the particles are large (~1 cm in diameter), and these particles would completely block a smaller diameter beam. Measurements indicate that a larger beam diameter does, in fact, provide a higher

duty cycle for transmitted signal even if the amplitude of the signal is somewhat diminished.

### **Additional Details**

The NEL lasers are contained in a fiber-coupled, 14-pin butterfly package with an integrated thermoelectric cooler and optical isolator, and are driven near 20mW with standard current and temperature controllers (ILX Lightwave). The VCSEL (Avalon Photonics) provided 200 microwatts of single mode power at 760 nm and was efficiently fiber-coupled (Melles-Griot Electro-optics, Boulder, CO).

The multiplexer is similar in design to Zolo Technologies Zmux 44-channel, echelle-grating-based optical multiplexer for telecommunications applications. The multimode demultiplexer is similar in design to the multiplexer; however, it incorporates multimode fiber on its input and output. The switches for this technical demonstration are purchased from Newport. The demultiplexed channels are routed back to individual detectors on multimode fiber. The NIR detectors are Fermionics fiber-coupled InGaAs detectors (uncooled), and the 760 nm detector is an uncooled, fiber-coupled silicon detector (Hamamatsu).

### **Results**

Laser transmission varies widely depending on position and time. The signal is intermittent due to partial obscuration of the laser light from particles passing through the beam. The expanded beam diameter (30 mm) allows light to transit the boiler with a higher duty cycle providing light for analysis on a more consistent basis since only a portion of the beam is blocked by coal dust and fly ash at any given time. At position A the average laser transmittance is  $1-5 \times 10^{-4}$ ; however, the instantaneous transmission

ranges from zero ( $10^{-6}$ ) to  $2 \times 10^{-3}$ . We find sufficient signal for processing with a  $\sim 50\%$  duty cycle at position A and with an 85% duty cycle at position B. Unsuccessful attempts were made to measure wavefront distortion of the beam with a Shack-Hartman analyzer, indicating the severity of the distortion. (Hence, the inability to couple light with good efficiency into single mode fiber.)

The demultiplexer provides a spectral filter ( $\sim 0.8$  nm FWHM), which effectively eliminates background emission interference from the highly luminous fireball. As a result, the laser signal is  $\sim 100$  times larger than the background emission noise in our measurements. This is in direct contrast with the work of Teichert et al. who used interference filters to separate multiplexed beams, and observed a background emission noise that was within a factor of three of the transmitted laser signal for their experiments.[5]

Figure 2 shows a portion of an experimental water absorption spectrum with the baseline corrected for the increase in diode output power as a function of the current tuning ramp as well as any residual filter function slope. Twenty thousand scans are averaged in 10 seconds to produce one data set. The data processing program selects data for full processing based upon the power level detected. As mentioned above, sufficient power is received to process data approximately 50% of the time in position A and 85% of the time in position B. HITEMP simulations of this data show fairly major discrepancies indicating the need for further study into the quantitative spectroscopy of these fairly weak lines; however, the temperature in the flame front of the boiler appears to be roughly 1700K. Quantitative line strength measurements are currently under way as a collaborative effort between Zolo and the Hanson group at Stanford.

Figure 3 shows an absorption scan taken in the 1559 nm ( $6412\text{ cm}^{-1}$ ) region near the R(24) line of the CO (2,0) overtone while Figure 4 shows an experimental oxygen spectrum.

### **Conclusions**

Preliminary results indicate that the multiplexed spectroscopy sensor described here has much potential. However, in order to quantify  $\text{H}_2\text{O}$  concentration and temperature with sufficient accuracy, a significant amount of laboratory experimentation will need to be completed to confirm assignments, measure linestrengths, and determine line-broadening parameters. These efforts are currently under way.

### **Acknowledgement**

The Stanford University participate was made possible by support from the Global Climate Environmental Program.

## References:

1. Private conversation with Pegasus, Technologies, Inc., Mentor Ohio, CEO Gary Nicholson.
2. E.R. Furlong, D.S. Baer, and R.K. Hanson, "Real-time adaptive combustion control using diode-laser absorption sensors" Twenty-seventh Symposium (International) on Combustion/ The Combustion Institute, 1998/pp. 103-111.
3. M.G. Allen, B.L. Upschulte, D.M. Sonnenfroh, W.J. Kessler, and P.A. Muhall, "Overview of diode laser measurements in large-scale test facilities," paper AIAA-2000-2452, presented at the 21<sup>st</sup> Aerodynamic Measurement Technology and Ground Testing Conference, Denver, CO, 19-22 June 2000.
4. J.A. Silver and D.J. Kane, Meas. Sci. Technol. 10 (1999) 845-852.
5. H. Teichert, T. Fernholz, and V. Ebert, Applied Optics 42(12) (2003) 2043-2051.
6. Y. Deguchi, M. Noda, M. Abe, and M. Abe, Proc. Combust. Inst., 29 (2002) 147-153.
7. S.T. Sanders, J.A. Baldwin, T.P. Jenkins, D.S. Baer, and R.K. Hanson, Proceeding of the Combustion Institute, 28 (2000) 587-594.
8. J.T.C. Liu, J.B. Jeffries, R.K. Hanson, S. Creighton, J.A. Lovett, and D.T. Shouse, "Diode laser absorption diagnostics for measurements in practical combustion flow fields" **paper AIAA-2003-4581** 39<sup>th</sup> AIAA/ASME/SAE/ASEE Joint Propulsion Conference and Exhibit, July 20-23, 2003, Huntsville, AL.
9. J. Wang, M. Maiorov, J. Jeffries, D. Z. Garbuzuov, J. Connolly, and R. K. Hanson, Measurement Science and Technology **11**, 1576-1584 (2000).
10. D.B. Oh, M.E. Paige, and D.S. Bomse, Applied Optics 37 (12) (1998) 2499-2501.

11. L.S. Rothman, C.P. Rinsland, A. Goldman, S.T. Massie, D.P. Edwards, J.-M. Flaud, A. Perrin, C. Camy-Peyret, V. Dana, J.-Y. Mandin, J. Schroeder, A. McCann, R.R. Gamache, R.B. Wattson, K. Yoshino, K.V. Chance, K.W. Jucks, L.R. Brown, V. Nemtchinov, and P. Varanasi, "The HITRAN molecular spectroscopic database and HAWKS (HITRAN ATMOSPHERIC WORKSTATION): 1996 edition," J. Quant. Spectrosc. Radiat. Transfer 60 (1998) 665-710.

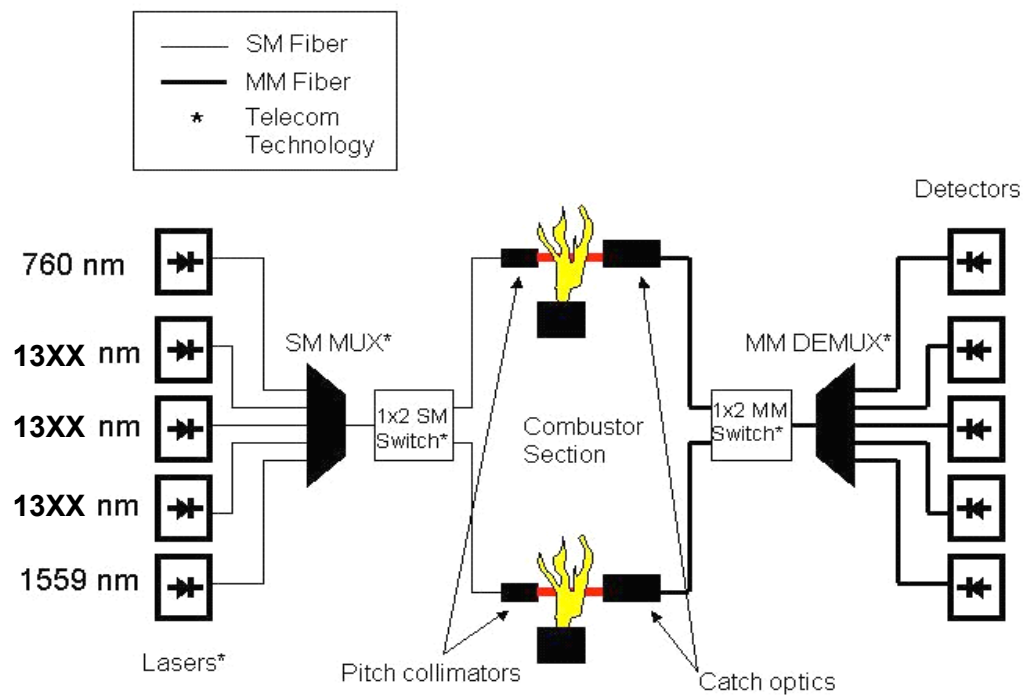

**Figure 1:** Schematic diagram of Zolo MSS combustion sensor

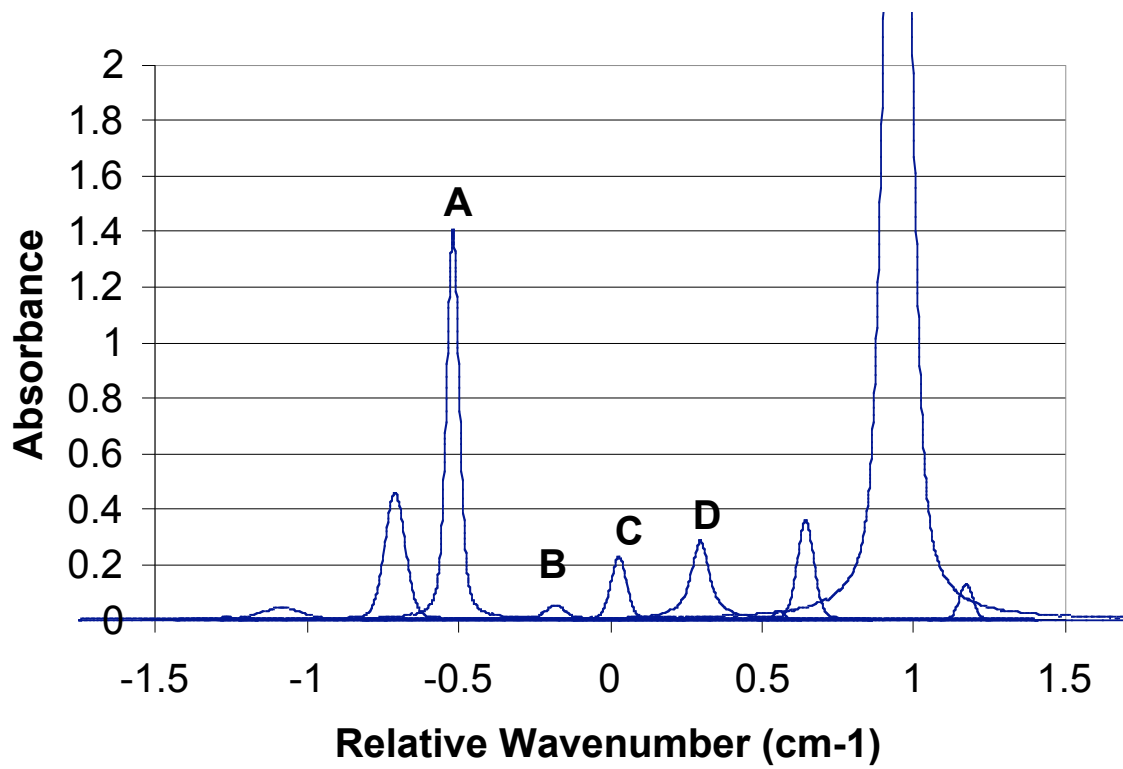

**Figure 2:** Experimental wavelength scan of the 13xx nm region.

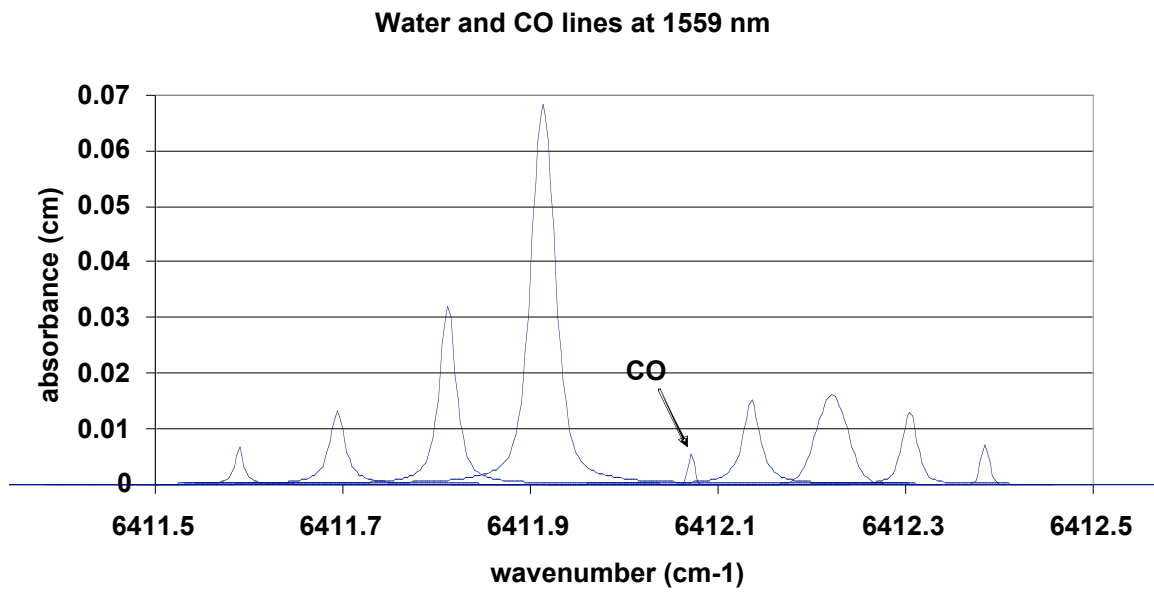

**Figure 3:** Wavelength scan of the region around the CO R(24) and R(25) lines.

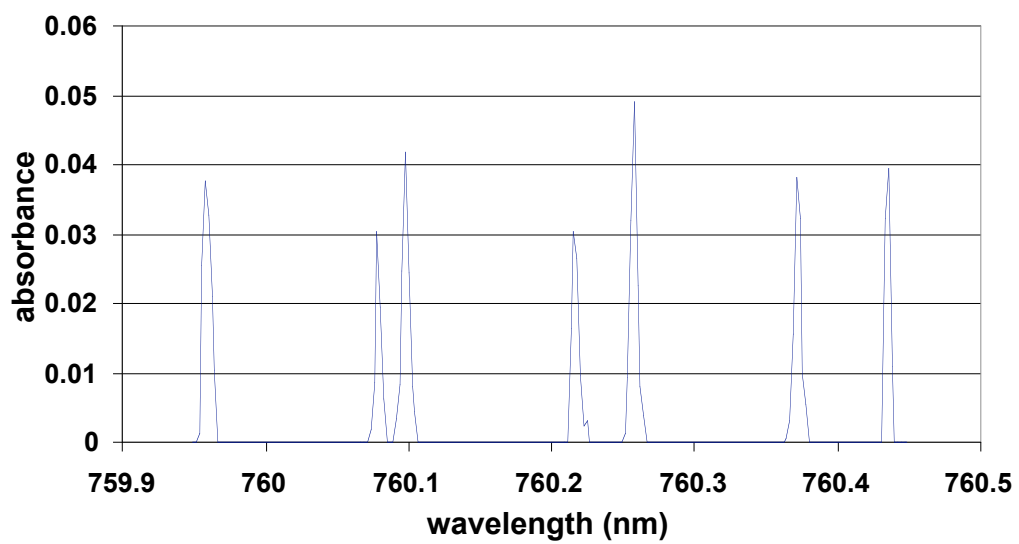

**Figure 4:** Experimental wavelength scan of oxygen in the 760 nm region.